

PREVENTION AND PREPAREDNESS OF THE MESSINA - REGGIO CALABRIA STRAIT: AN EARTHQUAKE FORECASTING AND DIDACTIC PROJECT

FRANCESCO DI STEFANO ^{a *}, GIOACCHINO GIAMPAOLO GIULIANI ^a,
DIMITAR OUZOUNOV ^{a b}, DANIELE CATALDI ^{a c}, CRISTIANO FIDANI ^{a d},
ANGELO D'ERRICO ^a AND GIULIA FIORAVANTI ^{a e}

ABSTRACT. This contribution is addressed to an introductory university course on the correlation existing between radon emission and earthquakes processes held following a flipped-class approach where students receive didactic materials prior to face-to-face lessons. This research was initially started to investigate the real correlation between Radon emission from the Earth and the occurrence of strong earthquakes by using measurements of hourly Radon flow variation. During quiet seismogenic conditions, we observe an unvarying level of Radon emission in the air. Before a strong earthquake, substantial variations of Radon (^{222}Rn) concentration have been observed in the air, probably because of the increase of thermodynamic energy inside the Earth. The physical processes affecting earthquakes are still not fully understood; therefore, we are interested in investigating a wide variety of signals observed before an earthquake, ranging from chemical, electric, and magnetic variations. The goal is to be able to estimate the earthquake magnitude, timing also location in advance with a good approximation. The experimental observation and research studies were carried out by G. Giuliani Permanent Foundation since 2002 in Abruzzo. The innovative methodology of observations with Gamma detectors allowed us to reveal a close correlation between the different physical phenomena during the preparation phase of strong earthquakes. We master the methodology of measuring the hourly flow of ^{222}Rn gas decay, which provides a good correlation with the occurrence of strong earthquakes. To advance the reliability of our assessment, we added more parameters to our observations, such as magnetic and RF. The joint analysis advances our understanding of the processes underlying the earthquake occurrence. The experimental observation of Radon has been tested for more than a decade in the Abruzzo region. The initial results provided the baseline of reliable correlation between radon variations and earthquakes that could be used as an alert mechanism for the forthcoming seismic events. The multiparametric approach of detecting pre-earthquakes signals provided the robustness in detecting the earthquake preparation phase. There are no doubts that by expanding the network of gamma sensors, we achieve much better signal detection, which is critical for the better spatial correlation of Radon variations with the earthquake processes.

1. Introduction

There are multiple chemical-physical events before a strong earthquake occurs, one of which is the increase of ^{222}Rn in the atmosphere. In situations of seismogenic calm, there is an almost constant flow of ^{222}Rn . At the same time, when there is an evident crustal dynamical activity, such as variations in pressure accumulations of energy, etc., there is a non-trivial increase in the emission of ^{222}Rn .

Short, mid, and long-term Radon measurements can give information on the pattern with which the concentration varied throughout the measurement interval, taking in count the external influences on ^{222}Rn variations. (Miles 2001; Groves-Kirkby *et al.* 2006) Variations of the Rn concentration in air is caused by changes of the Radon exhalation rate from surfaces, which in turn can be caused by changes of environmental parameters, e.g.: atmospheric pressure, temperature, relative humidity, elevation, air drafts, gamma radiation (Dueñas *et al.* 1997; Singh *et al.* 2001; Kitto 2005; Omori *et al.* 2009; Sorimachi *et al.* 2009). Radon concentration may be strongly affected by seasonally effects, and several publications report long-term measurements on Radon concentration, where the influence of the seasonal and diurnal effects on the Radon concentration is well studied (Bochicchio *et al.* 2005; Gervino *et al.* 2007; Kullab *et al.* 2009; Omori *et al.* 2009; Khan *et al.* 2010). We focused our attention on Rn indoor variations, continuously monitored, that involve the automatic taking of measurements at closely spaced time intervals, over a long period. The most commonly used instruments for continuous Rn monitoring, since the mid-1970's till today, for the characterization of the indoor Rn environment, consist of scintillation cells, pulse and current ionization chambers, electret ionization chambers, alpha track detectors, and solid-state alpha detectors (Nikolaev and Ilic 1999; Arafa *et al.* 2005; Gervino *et al.* 2007). The most typical disadvantages of the measurement techniques cited above are due to improper calibration of the system, malfunction of the counting systems, nonlinear response, low detection limits, high costs of the apparatus. Without using a particular set-up, most of these techniques detect alpha emitters without energy discrimination. Solid-state detectors can yield information about the energy of individual particles or photons of radiation (Hosseini Pooya *et al.* 2005; Yu *et al.* 2005). It is possible to determine the Radon concentration by counting alpha and gamma rays from Rn daughter decay using spectroscopic techniques. Alpha, beta, and gamma radioactivities are the detectable phenomena, either independently or simultaneously, and many researchers accomplished more than one technique at the same time, to have more reliable results (Paul *et al.* 1999; Plastino *et al.* 2002; Papp 2006).

It is possible to distinguish Rn itself or the daughter concentrations by discriminating between the energy of the particles emitted. Alpha spectroscopy is used to detect Rn itself and one of its daughters, ^{218}Po . ^{222}Rn decays by emitting an alpha particle of 5.49MeV to give ^{218}Po that, in turn, decays to ^{214}Pb by emitting an alpha particle of 6.00MeV (see Fig. 1).

Gamma spectroscopy is used for the indirect Rn determination. Radon decay-product concentrations were determined as the weighted values from 295keV and 352keV for ^{214}Pb and 609 , 1120 and 1764keV for ^{214}Bi (see Fig. 1) photopeaks. Plastic scintillators are the most common systems used for gamma counting (L'Annunziata 2003).

Gamma detectors most often have upper and lower energy discriminator circuits and, when used correctly as single-channel analyzers, can provide information on the gamma

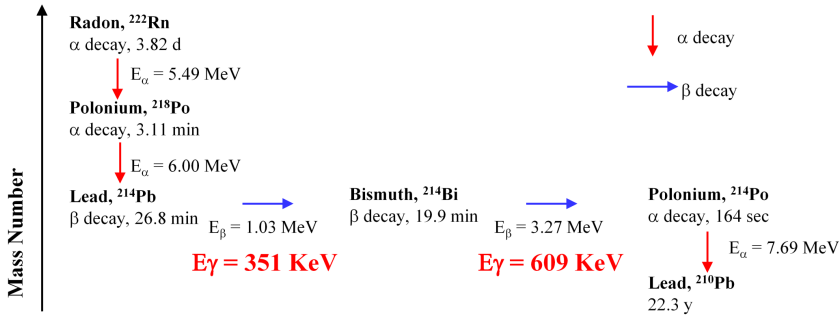

FIGURE 1. Decay chain about Radon

energy and identify the radioactive material. Experimental research conducted in Abruzzo from 2002 to 2009, through gamma-type detectors (PM-4 and PM-2), allowed to acquire important information on ²²²Rn anomalies in correlation with the occurrence of earthquakes. In recent years, the search for new correlations that would prove the data already obtained, through gamma-type detectors, has expanded to the field of electromagnetism and radio frequency, with the help of Radio Direction Finding (RDF)sensors.

2. New Gamma Detectors

2.1. Description. We describe a new Radon sensor, based on gamma detection of Radon decay products.

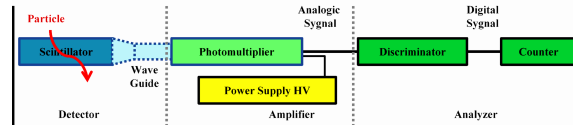

FIGURE 2. Block diagram of the instrument

Our device is divided into three sections: a gamma detector, an amplifier system and an analyzer one. The gamma detector (Fig. 2) is a plastic scintillator, NE110 or NE102 with a total volume of 800 or 600cm³. The characteristics of the commercial scintillator used in the equipment are a time of response of 2.4ns, and light emission at 423nm, which lies at the lower end of the violet. The response to light is 65%, compared to anthracene. It is an organic crystal, which has the characteristic of having the highest response among all the organic scintillators. The plastic scintillator is housed into a container made of solid lead (*i.e.*, not radioactive), as shown in Fig. 3, of 7 cm thickness. The container is covered with a thin layer of Mylar (4μm), in order to reduce or eliminate the presence of characteristic fluorescence X – rays from the lead shield. The plastic scintillator is coupled with four or two photomultipliers (Photonis XP3462b). They are placed on opposite walls of the lead box, with a specific gain, given from suppliers of ≈ 2x10⁶.

The present paper aims to furnish the contents for a lecture on radon radioactivity in the perspective of clarifying the correlations existing with seismic effects.

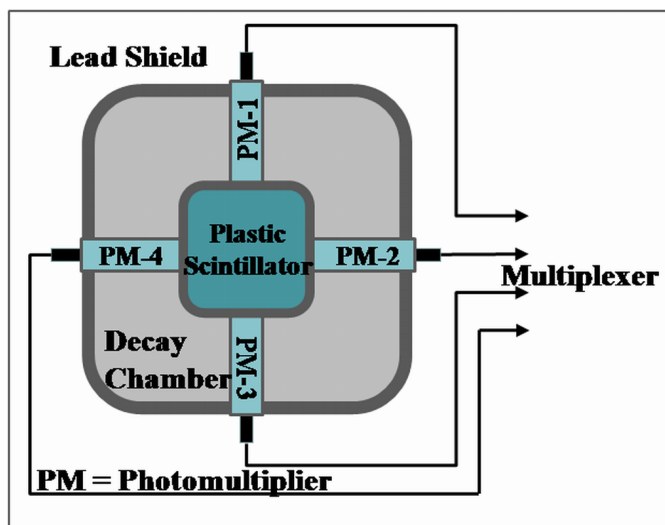

FIGURE 3. PM-4 detector section scheme

The ^{222}Rn decays emitting an alpha particle of 5.49MeV , and generating the “Radon progeny” that consists in ^{218}Po (alpha decay, the half-life of 3.11 min), ^{214}Pb (beta decay, the half-life of 26.8 min), ^{214}Bi (beta decay, the half-life of 19.9 min), and ^{214}Po that continues the decay chain. The ^{214}Pb and ^{214}Bi beta decays are followed by a typical gamma emission at 351KeV and 609KeV , respectively (see Fig.1). In our methodology, we consider the gamma rays activity that follows the decay of ^{222}Rn progeny, and we limit our energy window of analysis within the range of $250 - 700\text{KeV}$, which includes the response of gamma rays photo peaks for ^{214}Pb and ^{214}Bi . The gamma system utilized in this investigation was calibrated for performing readings, cutting off the signals due to higher energy particles, which could affect the measurement. The output signals are counts per second, and the acquisition time of 600 seconds is chosen. Readout units are counts per 7200 sec (2 hours), or Counting Rate, calculated on the counts average any two hours. During the first phase of our research we tested the instrument gain adjustment by using a γ -ray emitting reference source of ^{58}Co with an energy peak of 0.321MeV (from CAEN). The photomultiplier’s signal was analyzed by an ADC (Analog to Digital Converter) that gives back the energy spectrum.

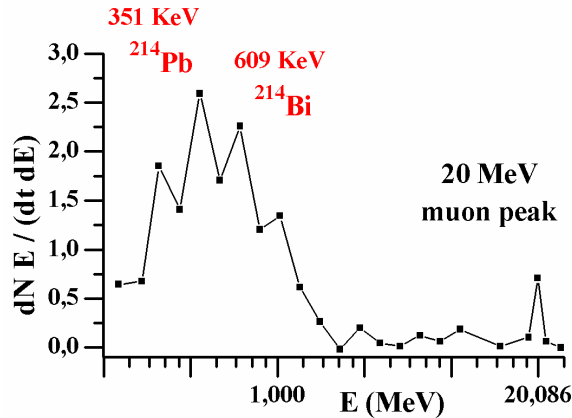

FIGURE 4. Energy spectrum obtained from the device

In Fig.4 it is shown the differential spectrum obtained with the AD Converter, reporting the gamma flashes (N) per second as a function of the energy. The spectrum evidences the characteristic peak due to gamma emission of the reference element at 0.321MeV .

The detector has a resolution ($FWHM$) of 460keV for the 321keV reported on Fig. 4, by using our experimental set-up, where it is possible to evidence the peaks due to Radon daughters (^{214}Pb and ^{214}Bi) coming from Rn decays, in typical energy of 351 and 609KeV , respectively. The muon peak at specific energy of 20MeV may act as a reference for the energy calibration of the system.

On Fig.?? it is shown the integral spectra simultaneously obtained by PM-2 and PM-4, reporting the integral counts per second of the shielded detector, in the energy range of $0, 13 - 24\text{MeV}$; the difference in counting rate is due to the use of 2 or 4 photomultipliers coupled to the plastic scintillator. The integral counting rate of the shielded detector, in the energy range of $0, 13 - 24\text{MeV}$, is $0,62\text{c/s}$, which is a good value for a passive shield.

As we can see, the system shows a linear response of PMs in the range chosen, but for PM-4 the variations are more pronounced than for PM-2, allowing us to perform our measurements with better sensitivity on counting rate response.

2.2. Effect of the lead shield. Particular care was paid to our γ -ray apparatus to avoid external influences on Radon emanation. The device was installed in a closed room 3meters under the ground level and 10cm above the floor. In indoor Rn measures, concentration and rate of propagation are affected by changes in atmospheric temperature and pressure. In order to have better data, it is fundamental to monitor weather conditions, *i.e.*, relative humidity and temperature of the ambient, that may influence the rate of Radon flux. The presence of ventilation systems should cause a drastic variation of Radon concentration (Chao *et al.* 1997), so the instrument has to be isolated from the outside. Thus, involves ensuring that windows and external doors are kept closed for the duration of the measurements, external-internal air exchange systems and air conditioning systems, that recycle interior air, are not operated. Cosmic-rays produce a natural background in the detector, but their nucleonic component is reduced to a negligible level already with a few m w.e., while the

much more penetrating cosmic-ray muon part needs much larger overburdens for a substantial reduction. The cosmic ray-induced background was reduced by installing the detector in an underground laboratory, where the concrete floors should shield as much as possible from cosmic rays, even if the muons penetrate the lead shield producing background in the detector (Laubenstein *et al.* 2004; Hurtado *et al.* 2006; Dragićaù *et al.* 2008; Udovičića *et al.* 2009). We measured the integral spectrum obtained with a different thickness shield of lead chosen to verify the shielding effect on our measurements and in order to minimize the natural radioactivity coming from the environment (Hurtado *et al.* 2006). The integral background counting rate from 0, 13 to 24MeV is plotted in Fig. 5.

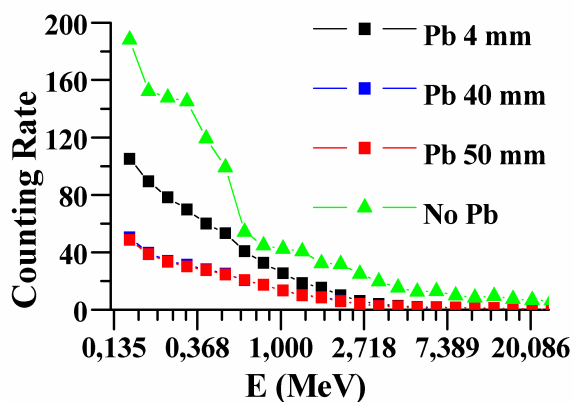

FIGURE 5. Effect of lead thickness on Rn measurements

We made measurements with different lead box thickness: *noPb*, *4mm*, *40mm* and *50mm* thickness. By looking at the Fig.5 we noticed that by putting the lead thickness we register a pronounced decreasing in counting rate, and enhancing the thickness to *40mm*, and over, the difference is undetectable (the two spectra with *40* and *50* mm of lead are overlapped, the red line hides the blue one). The integral background is reduced from $3.63c/s$ to $0.62c/s$ in the $0, 13 - 24MeV$ energy range; this means that the lead shield thickness of about *7cm* is suitable for reducing the gamma background by a factor of about 6, in the interest energy window. The lead box with *7cm* thick walls is the ideal compromise to get inside the gamma rays with still considerable energy and, at the same time, to shield the entire environmental radiation (due to other decays) that would make a significant mistake, all without having to let in air.

3. Data

We started measuring Radon variations, continuously monitored, over a medium-long period. Continuous sampling was performed by two detectors located in the Abruzzo Region. The two devices are placed one in **Coppito** (Lat. + $42^{\circ}22'N$ Long. + $13^{\circ}20'E$; $650ma.s.l.$), a small village *8km* far from L'Aquila city, the second one in **Avezzano** (Lat. + $42^{\circ}03'24''N$; Long. + $13^{\circ}24'12''E$; $700ma.s.l.$) about *42km* far from Coppito. The graph in Fig. 6 shows the raw data from the gamma detectors in the two different stations, collected in a four

months period (March-June 2004). The maximum instrumental error is 2000 Counting Rate any 7200sec, due to electronic noise, while the signal collected ranges between a minimum of 110000 and a maximum of 180000 counting rate for PM-4, so the maximum statistical error is $\sqrt{180000} = 424$ counting rate, that is 0,2%.

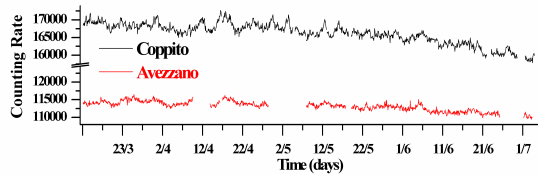

FIGURE 6. Raw data from Coppito and Avezzano stations (March-June 2004)

The two stations are located in environments that are different for external factors such as soil moisture and humidity, while for atmospheric pressure and temperature variations the influence is quite similar. Despite the different environments that may produce severe influences, the recorded raw data from the two stations show a decreasing trend from March to June, as expected when the temperature increase for seasonal variations. There are differences in the absolute value of the two signals because in Coppito, a PM-4 is working with four photomultipliers, while in Avezzano, a PM-2 is running with only two photomultipliers, but we can consider the relative variations from averages (Fig.7).

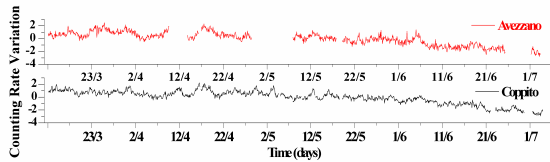

FIGURE 7. Counting Rate Variation (March-June 2004)

The relative counting rate variations were calculated by the formula $(X - \langle X \rangle) / \sigma$ where $\langle X \rangle$ is the mobile average calculated on the day, and σ is the standard deviation calculated over a week. For both plots there are some missing data caused by external supply interruptions, followed by a recalibration of the system. During our tests, we operated the measurements by fluxing air into the instrument box, and we observed an increase in the counting rate. In Fig.8 it is shown the counting rate in the presence of air flux, measured from PM-4 device located in Coppito, in the period of July-December 2004, where we observed a counting rate increasing of ~ 1.5 times when we flux air in (as shown in the zoom-in section of Fig.8). The external air flux enhances the natural background component due to all the Radon in the environment (that is the only gaseous radioactive element) a dirtier signal with higher error. Thus confirms that our experimental set-up is fit to obtain useful information from the environment, not affected by natural radioactivity background.

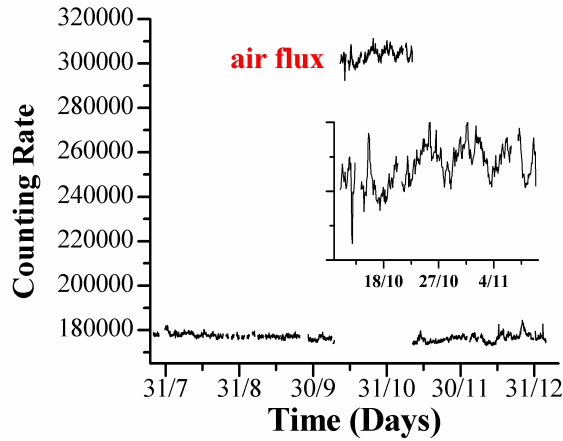

FIGURE 8. Test with air flux (July-December 2004)

We also show the data collected in 2006 from two stations (the second one was placed in the Gran Sasso National Laboratory, 20km east to Coppito, 900 m a.s.l.) for a long period (1 year). The relative counting rate variations were calculated by the formula $(X - \langle X \rangle) / \sigma$ where $\langle X \rangle$ is the mobile average calculated on the day and σ is the standard deviation calculated over a week.

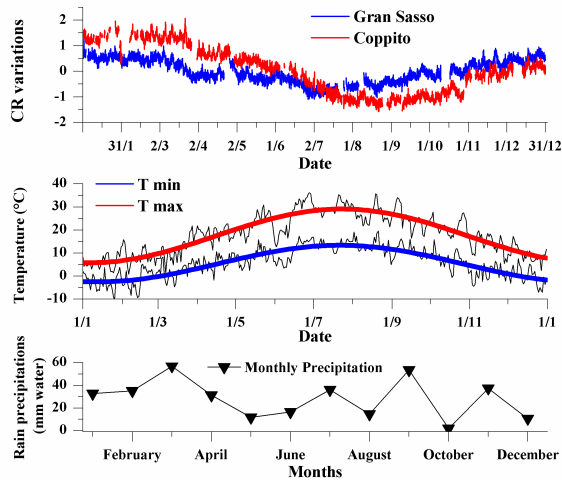

FIGURE 9. Data collected in 2006 from Coppito and Gran Sasso stations

Typical seasonal variation of Rn and its variation with ambient temperature and rain precipitations are reported in Fig. 9; the second plot shows the temperature variations for 2006, the T min, and T max trends in L'Aquila, while the third plot shows the monthly rain

precipitations (font: <http://cetemps.aquila.infn.it>). As expected, an increase of temperature leads to a minimum of Radon emanation, as the counting rate variation is in inverse relation with ambient temperature. Precipitations do not seem to play an important role (Giuliani and Fioravanti 2013).

4. Teaching Approach

As far as the transmission of contents related to the correlation between Radon emission and earthquakes is concerned, we believe that a multi-task approach based on the sequence watching, reading, hearing and doing constitutes the most effective procedure to transmit contents to students. In particular we propose at first to promote student's curiosity and interest through a learning by watching approach; then comprehending and learning properties, rules and concepts through a flipped classroom approach where didactic material is given to students before to face-to-face lessons; finally to explain how to perform radiological analyses with different techniques, *i.e.*, learning by doing/thinking.

5. Conclusions

In conclusion, we present an overview of gamma sensors for indirect Rn measurements, continuously monitored in closed spaces located underground, without ventilation. The device is characterized in reliability by comparing it with a commercial instrument (Rad7). The experimental set-up and local conditions of measurement provide minimization of the natural background radioactivity. The information obtained from Radon emissions is interesting from the point of view of observing Radon anomalies, not affected by environmental radioactivity. As shown for long-period measurements, it is fundamental to monitor climate conditions that have a severe influence on Radon emanation. With reference to the topic dealing with the correlation between Radon emission and earthquakes, the authors believe that the proposed approach can be successful in a multitask teaching program addressed to introduce university students into the applications of radon radioactivity.

Acknowledgments

This work was done with a lot of commitment and dedication and, above all curiosity on the part of the entire research team.

We are personally grateful to Prof. S. Magazù for allowing us to participate in this series of scientific publications. We also thank the entire "Accademia dei Peloritania dei Pericolanti - class of mathematical, physical sciences". We wish to thank Dr. F. Di Stefano for drafting this article, and we thank the entire Scientific Council of the "Giuliani ONLUS Foundation" for reviewing this manuscript under the constant support and spur of the President of the foundation, G. Giuliani.

References

- Arafa, W., Badran, H., and El Samman, H. (2005). "Effect of moving air and variable radon concentration on the response of charcoal canister". *Radiation Measurements* **40**(2-6), 662–665.
- Bochicchio, F., Campos-Venutia, G., Piermattei, S., Nuccetelli, C., and Risica, S. (2005). "Annual average and seasonal variations of residential radon concentration for all the Italian regions". *Radiation Measurements* **40**(2-6), 686–694. DOI: [10.1016/j.radmeas.2004.12.023](https://doi.org/10.1016/j.radmeas.2004.12.023).
- Chao, C., Tung, T., and Burnett, J. (1997). "Influence of ventilation on indoor radon level". *Building and Environment* **32**(6), 527–534. DOI: [10.1016/S0360-1323\(97\)00017-6](https://doi.org/10.1016/S0360-1323(97)00017-6).
- Dragićaū, A., Jokovića, D., Banjanac, R., Udovičić, V., Panić, B., Puzović, J., and Aniĉin, I. (2008). "Measurement of cosmic ray muon flux in the Belgrade ground level and underground laboratories". *Nuclear Instruments and Methods in Physics Research Section A: Accelerators, Spectrometers, Detectors and Associated Equipment* **591**(3), 470–475. DOI: [10.1016/j.nima.2008.02.053](https://doi.org/10.1016/j.nima.2008.02.053).
- Dueñas, C., Fernández, M. C., Carretero, J., Liger, E., and M., P. (1997). "Release of ²²²Rn from some soils". *Annales Geophysicae* **15**, 124–133. DOI: [10.1007/s00585-997-0124-0](https://doi.org/10.1007/s00585-997-0124-0).
- Gervino, G., Barca, D., Bruno, S., Bonetti, R., and Manzoni, A. (2007). "Annual average and seasonal variations of indoor radon concentrations in Piedmont (Italy) using three different detection techniques". *Nuclear Instruments and Methods in Physics Research Section A: Accelerators, Spectrometers, Detectors and Associated Equipment* **572**(1), 254–256. DOI: [10.1016/j.nima.2006.10.362](https://doi.org/10.1016/j.nima.2006.10.362).
- Giuliani G. and Attanasio, A. and Fioravanti, G. (2013). "Gamma Detectors for Continuous Monitoring of Radon". *Journal of International Environmental Application & Science* **8**(4), 541–550.
- Groves-Kirkby, C., Denman, A., Crockett, R. G. M., Phillips, P. S., Woolridge, A. C., and Gillmore, G. K. (2006). "Time-integrating radon gas measurements in domestic premises: comparison of short-, medium- and long-term exposures". *Journal of Environmental Radioactivity* **86**(1), 92–109. DOI: [10.1016/j.jenvrad.2005.07.008](https://doi.org/10.1016/j.jenvrad.2005.07.008).
- Hosseini Pooya, S., Afarideh, H., Kardan, M., and Taheri, M. (2005). "Design of an alpha spectrometry system for separated measurement of radon/thoron daughters' concentration by lexan PC SSNTD". *Nuclear Instruments and Methods in Physics Research Section A: Accelerators, Spectrometers, Detectors and Associated Equipment* **594**(1), 44–49.
- Hurtado, S., García-León, M., and García-Tenorio, R. (2006). "Optimized background reduction in low-level gamma-ray spectrometry at a surface laboratory". *Applied Radiation and Isotopes* **64**(9), 1006–1012. DOI: [10.1016/j.apradiso.2006.01.008](https://doi.org/10.1016/j.apradiso.2006.01.008).
- Khan, S., Matiullh, M., and Ghauri, B. (2010). "Comparison of seasonal and yearly average indoor radon levels using CR-39 detectors". *Radiation Measurements* **45**(2), 247–252. DOI: [10.1016/j.radmeas.2010.01.004](https://doi.org/10.1016/j.radmeas.2010.01.004).
- Kitto, M. (2005). "Interrelationship of indoor radon concentrations, soil–gas flux, and meteorological parameters". *Journal of Radioanalytical and Nuclear Chemistry* **264**, 381–385. DOI: [10.1007/s10967-005-0725-6](https://doi.org/10.1007/s10967-005-0725-6).
- Kullab, M., Al-Bataina, B., A.M., I., and Abumurad, K. (2009). "Seasonal variation of radon-222 concentrations in specific locations in Jordan". *Radiation Measurements* **34**(1–6), 361–364. DOI: [10.1016/S1350-4487\(01\)00186-X](https://doi.org/10.1016/S1350-4487(01)00186-X).
- L'Annunziata, M. (2003). *Handbook of radioactivity analysis, second ed.* Academic Press.
- Laubenstein, M., Hult, M., Gasparro, J., Arnold, D., Neumaier, S., Heusser, G., Köhler, M., Povinec, P., Reyss, J.-L., and Schwaiger M. and Theodorsson, P. (2004). "Underground measurements of radioactivity". *Applied Radiation and Isotopes* **61**(2-3), 167–172. DOI: [10.1016/j.apradiso.2004.03.039](https://doi.org/10.1016/j.apradiso.2004.03.039).

- Miles, J. (2001). "Temporal variation of radon levels in houses and implications for radon measurement strategies". *Radiation Protection Dosimetry* **56**(4), 207–210. DOI: [10.1093/oxfordjournals.rpd.a006449](https://doi.org/10.1093/oxfordjournals.rpd.a006449).
- Nikolaev, V. A. and Ilic, R. (1999). "Etched track radiometers in radon measurements: a review". *Radiation Measurements* **30**(1), 1–13.
- Omori, Y., Tohbo, I., Nagahama, H., Ishikawa, Y., Takahashi, M., Sato, H., and Sekine, T. (2009). "Variation of atmospheric radon concentration with bimodal seasonality". *Radiation Measurements* **44**(9–10), 1045–1050. DOI: [10.1016/j.radmeas.2009.10.077](https://doi.org/10.1016/j.radmeas.2009.10.077).
- Papp, Z. (2006). "An intercomparison between gross α counting and gross β counting for grab-sampling determination of airborne radon progeny and thoron progeny". *Nuclear Instruments and Methods in Physics Research Section A: Accelerators, Spectrometers, Detectors and Associated Equipment* **558**(2), 569–575. DOI: [10.1016/j.nima.2005.11.185](https://doi.org/10.1016/j.nima.2005.11.185).
- Paul, A., Röttger, S., Honig, A., Sulima, T., Buchholz, A., and Keyserac, U. (1999). "Measurement of short-lived radon progenies by simultaneous $\alpha\gamma$ – spectrometry at the German radon reference chamber". *Nuclear Instruments and Methods in Physics Research Section A: Accelerators, Spectrometers, Detectors and Associated Equipment* **343**(2-3), 303–312.
- Plastino, W., De Felice, P., and Notaristefani, F. de (2002). "Radon gamma-ray spectrometry with YAP:Ce scintillator". *Nuclear Instruments and Methods in Physics Research Section A: Accelerators, Spectrometers, Detectors and Associated Equipment* **486**(1-2), 146–149.
- Singh, K., Singh, M., Singh, S., Sahot, H., and Papp, Z. (2001). "Variation of radon (^{222}Rn) progeny concentrations in outdoor air as a function of time, temperature and relative humidity". *Radiation Measurements* **32**(2), 213–217. DOI: [10.1016/j.radmeas.2004.06.015](https://doi.org/10.1016/j.radmeas.2004.06.015).
- Sorimachi, A., Takahashi, H., and Tokonami, S. (2009). "Influence of the presence of humidity, ambient aerosols and thoron on the detection responses of electret radon monitors". *Radiation Measurements* **44**(1), 111–115. DOI: [10.1016/j.radmeas.2008.10.009](https://doi.org/10.1016/j.radmeas.2008.10.009).
- Udovičića, V., Grabeža, B., Dragića, A., Banjanaca, R., Jokovića, D., Panića, B., Joksimović, D., Puzovićb, J., and Aničina, I. (2009). "Radon problem in an underground low-level laboratory". *Radiation Measurements* **44**(9-10), 1009–1012. DOI: [10.1016/j.radmeas.2009.10.038](https://doi.org/10.1016/j.radmeas.2009.10.038).
- Yu, P., Nikezic, D., Ng, F., and Leung, J. (2005). "Long-term measurements of radon progeny concentrations with solid state nuclear track detectors". *Radiation Measurements* **40**(2-6), 560–568.

-
- ^a Foundation “G. Giuliani ONLUS”
Strada Vicinale di Bazzano, 11
67100, L’Aquila, Italy
- ^b CEESMO
Chapman University
Orange, CA, USA
- ^c Radio Emissions Project
Rome, Italy
- ^d Central Italy Electromagnetic Network
Contrada San Procolo
63847, Fermo, Italy
- ^e University of L’Aquila
Department of Physical and Chemical Sciences
Via Vetoio, loc. Coppito, 67100, L’Aquila (AQ), Italy
- * To whom correspondence should be addressed | email: fds290@gmail.com

Paper contributed to the international workshop entitled “New Horizons in Teaching Science”, which was held in Messina, Italy (18–19 november 2018), under the patronage of the *Accademia Peloritana dei Pericolanti*
Manuscript received 04 May 2020; published online 30 September 2021



© 2021 by the author(s); licensee *Accademia Peloritana dei Pericolanti* (Messina, Italy). This article is an open access article distributed under the terms and conditions of the [Creative Commons Attribution 4.0 International License](https://creativecommons.org/licenses/by/4.0/) (<https://creativecommons.org/licenses/by/4.0/>).